

M-LINE

M4.35

● ● ● ● 24.3 kW / 33 HP

TECHNICAL SPECIFICATIONS

Supplied as standard with instrument panel type MPA22BS2 (see page 103), four flexible engine mountings type KSTEUN75V (see page 48) and an oil sump pump.



All VETUS engines are certified according ISO 8178-1

Engine model	M4.35
* Max. output at flywheel (ISO 3046-1)	24.3 kW (33 hp)
* Max. output at propeller shaft (ISO 3046-1)	23.6 kW (32.1 hp)
Maximum rpm	3000
Max. torque	83.8 Nm/1700 rpm
Bore x stroke	78 mm x 92 mm
Displacement	1758 cm ³
Number of cylinders	4 in line
Combustion system	indirect injection
Compression ratio	22:1
Firing order	1-3-4-2
Intake	naturally aspirated
Electrical system	12 Volt - 110 Amps.
Cooling system (standard)	indirect cooling (keel cooling optional)
Gearbox, standard	TMC60P (2 / 2.5 / 2.94:1)
Gearbox options	ZF12M 2.14 / 2.63:1 TMC60A 2 / 2.5:1

Saildrive	SP60 2.15 / 2.38:1 SD10 2.23 / 2.49:1
Dry weight (incl. std. gearbox)	199 kg
Fuel consumption at 2500 rpm	252 g / kW.h (185 g / hp.h)
Max. backwards installation angle	15°
Max. lateral inclination angle;	
Continuously	25°
5 minutes max.	30°
Suction height of fuel lift pump	1.5 m
Calorifier connection kit	optional
Instrument panel (standard)	MPA22BS2
Warning lights and audible alarm	oil pressure, temperature (coolant and exhaust), charging current
Control light for	pre-heating/glow plugs
Electric circuit protection	fuse 10 Amps.
Certifications	EU-RCD II, BSO, SOLAS

* In accordance with ISO 8665

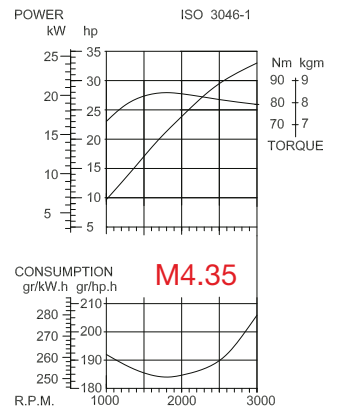
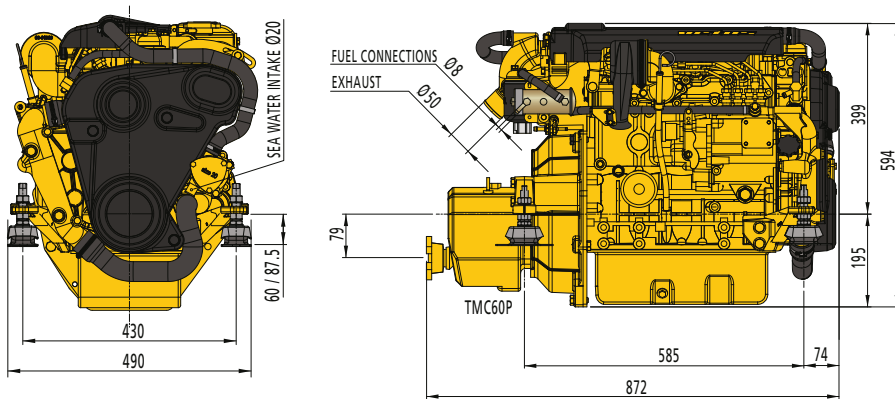

Certified within 5%